

DTC30

HYDRAULIC PILING RIG



GEAX DTC30

AGILITY ON SITE

COMPACT DESIGN

The DTC30, like all the Geax DTC series rigs is characterized by a very compact design which makes it the machine of choice for limited access, narrow and very low headroom jobsites.

UNIQUE ARCHITECTURE

The Geax DTC series are characterised by a long supporting boom and a sliding monolithic mast which encloses the kelly bar internally. This solution guarantees a stiffer and lighter design, enabling a great variety of tool positioning including long reach.

MANEUVERABILITY

With its compact dimensions and proverbial stability, the DTC30 can drill in any site including slopes, uneven terrains, and tight spaces. The higher maneuverability allows fast movements compared to a traditional rig.

HIGH PRODUCTIVITY

Thanks to the high maneuverability on site, and the efficiently engineered hydraulics with high quality components, the DTC30 offers superior performance relative to the size, while keeping very low running costs.

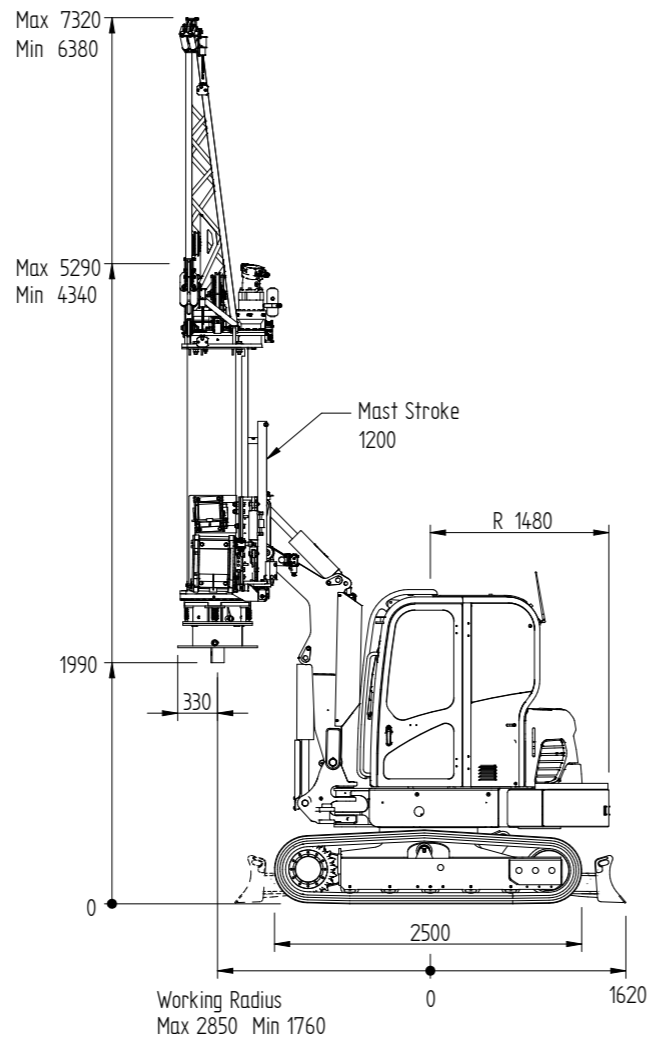

TECHNICAL DATA SHEET

BASE CARRIER

Engine	type	D24
Exhaust emission	EU EPA	Stage V Tier4f
Engine power	kW (hp)	44.3 (59.4)
Main pumps	l/min	144.9
Hydraulic pressure	bar	275

MAST

Forward tilt	deg	>10
Backward tilt	deg	>10
Lateral tilt	deg	± 6.5
Mast vertical stroke	mm - ft	1.200 - 3.9

WINCHES

Main winch line pull (1st layer)	kN - lbf	40 - 9.000
Aux winch line pull (1st layer)	kN - lbf	17 - 3.800

DRILLING

Max pile diameter ¹	mm - in	800 - 32
Std pile depth	m - ft	16 - 52.5
Max pile depth	m - ft	16 - 52.5
Rotary stroke on mast	mm - ft	-
Total rotary stroke	mm - ft	1.200 - 3.9
Min working headroom	mm - ft	4.340 - 14.2

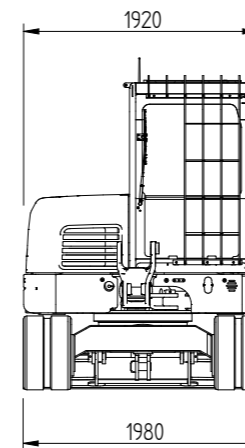

UNDERCARRIAGE

Tracks width	mm - ft	1.980 - 6.5
Tracks length	mm - ft	2.486 - 8.15
Track shoes	mm - ft	400 - 1.31
Tail radius	mm - ft	1.560 - 5.1

ROTARY HEAD

Torque (nominal)	kNm - lbf ft	25 - 18.440
Drilling speed	rpm	10 - 50
Spin-off speed	rpm	50

CROWD SYSTEM

Pull down force	kN - lbf	50 - 11.200
Extraction force	kN - lbf	52 - 11.700

TRANSPORT

Length	mm - ft	5.300 - 17.4
Width	mm - ft	1.980 - 6.5
Height	mm - ft	2.600 - 8.25
Weight	kg - lbs	9.500 - 20.950

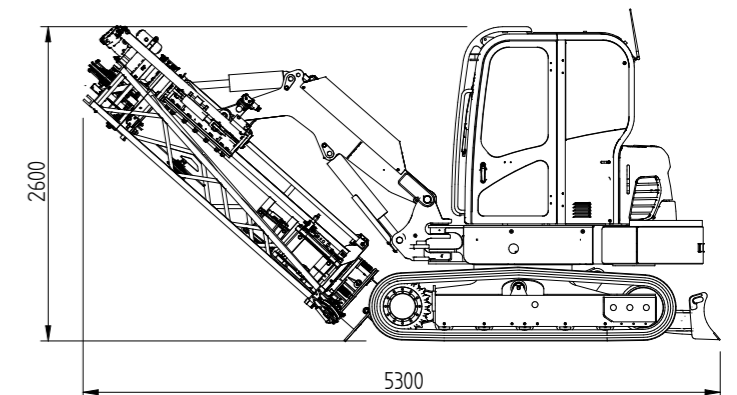

- Values are effective except where otherwise specified.
- Technical data are provided as indicative information only, they are subject to change without prior notice.

NOTES: 1. Recommended



WWW.GEAX.IT
email: info@geax.it
tel: +39 0717131953

GEAX srl
Contrada Passatempo 19
Montefano (MC) ITALY